

深圳市海芝通电子股份有限公司
Shenzhen Hi-Chipcom Electronics Co.,Ltd

聚合物锂电池规格书

客户型号(Model):iPhone5G

电 压(Voltage): 3.8V

标称容量(Nominal Capacity): 1440mAh

组合方式(Assembled): PCM+FPC+连接器

版本(Revision): A/0

日期(Date): 2017-09-22

客户(Customer):

PACK Registered/Date PACK编制/日期	PACK Checked/Date 审核/日期	Approved/Date 批准/日期

Customer Confirmation 客户确认	Date 日期

The Specification in Chinese and English respectively, if they have differences, the Chinese language version shall prevail.

本规格书为中英文双语，如有分歧，则以中文版本为准。

深圳市海芝通电子股份有限公司

Shenzhen Hi-Chipcom Electronics Co.,Ltd

Product Summary 产品概要

Scope and standard 适用范围及依据标准

Scope 适用范围

The specification shall be applied to Li-Polymer Battery, which is manufactured by Shenzhen Hi-Chipcom Electronics Co.,Ltd.

本规格书适用于深圳市海芝通电子股份有限公司生产的聚合物锂电池。

Standard 依据标准

本产品依据标准：GB31241-2014

The product is based on standard: GB 31241 - 2014

Production description 产品描述

Name 名称: lithium-ion polymer batteries (锂离子聚合物电池)

Mode 型号: iPhone 5G 3.8V/1440mAh

Cell 采用电芯: 锂离子聚合物 363290/1440mAh

Structure Drawing 电池结构图: 3.5*31*91(mm) \pm 0.2

Front view 正视图 (供参考): 哑黑色



深圳市海芝通电子股份有限公司

Shenzhen Hi-Chipcom Electronics Co.,Ltd

1、 Scope and standard 适用范围及依据标准

1.1 Scope 适用范围

The specification shall be applied to Li-Polymer Battery, which is manufactured by Shenzhen Hi-Chipcom Electronics Co.,Ltd.

本规格书适用于深圳市海芝通电子股份有限公司生产的聚合物锂电池。

Standard 依据标准

本产品依据标准：GB31241-2014

The product is based on standard: GB 31241 - 2014

2、 Specification 主要技术参数

NO 序号	Items 项目	Parameter 参数	Remarks 备注
2.1	Minimum Capacity 最小容量	1440mAh	Discharge:0.2C 放电 0.2C cut-off voltage:3.4V 截止电压 3.4V
	Rated Capacity 标称容量	1440mAh	
2.2	Energy 能量	5.47Wh	
2.3	Nominal Voltage 标称电压	3.8V	
2.4	Open Voltage 出厂电压	3.78V~4.05V	
2.5	Load Voltage 负载电压	≥3.8V	
2.6	Internal Impedance 内阻	≤200mΩ	AC 1KHz after standard charge 标准充电后 AC 1KHz 测试
2.7	Charge voltage 充电电压	4.3V	CC/CV
2.8	Standard charge current 标准充电电流	720mA	0.50 CC mode
2.9	Max charge current 最大充电电流	1440mA	1.0 CC mode
2.10	Standard discharge current 标准放电电流	288mA	0.2 CC mode
2.11	Max discharge current 最大放电电流	1440mA	1.0 CC mode
2.12	Discharge cut-off voltage 放电截止电压	3.4V (手机低压保护电压)	硬件欠压保护电压 2.5V
2.13	Quiescency current 静态电流消耗	<200uA	
2.14	Cycle Performance 电池循环寿命	≥300 次	剩余容量 80%以上
2.15	电池计量 IC 通讯协议	HDQ 单线协议	
	Operating Temperature	0~+45°C	Charge 充电

深圳市海芝通电子股份有限公司

Shenzhen Hi-Chipcom Electronics Co.,Ltd

2.16	工作温度	0~+45℃	Discharge 放电
2.17	Storage Temperature 贮存温度	0℃~+45℃	Less than 1 month 小于一个月
		10℃~+30℃	Less than 6 months 小于六个月
2.18	输出界面	iPhone 5G 专用	
2.19	Weight 重量	About 23.0±2.0 g	
2.20	外观尺寸	3.5*31*91(mm)±0.2	

3. Battery Performance Criteria 电池性能检查及测试

3.1 Appearance 外观

There shall be no such defect as scratch, flaw, crack, rust, leakage, which may adversely affect commercial value of battery.

电池外表面清洁，无电解液泄漏，无明显的划痕及机械损伤，无变形，无影响电池价值的其他外观缺陷。

3.2 Measurement Apparatus 测试设备要求

(1) Dimension Measuring Instrument 尺寸测量设备

The dimension measurement shall be implemented by instruments with equal or more precision scale of 0.01mm.

测量尺寸的仪器的精度应不小于 0.01mm

(2) Voltmeter 电压表

Standard class specified in the national standard or more sensitive class having inner impedance not less than 10 KΩ/V.

国家标准或更灵敏等级,内阻不小于 10 KΩ/V.

(3) Ammeter 电流表

Standard class specified in the national standard or more sensitive class. Total external resistance including ammeter and wire is less than 0.01Ω.

国家标准或更灵敏等级，外部总体内阻包括电流表和导线应小于 0.01Ω.

(4) Impedance Meter 内阻测试仪

Impedance shall be measured by a sinusoidal alternating current method(AC 1kHz LCR meter).

内阻测试仪测试方法为交流阻抗法(AC 1kHz LCR).

深圳市海芝通电子股份有限公司

Shenzhen Hi-Chipcom Electronics Co.,Ltd

standard Test Condition 标准的测试条件

Test should be conducted with new batteries within one month after shipment from our factory and the cells shall not be cycled more than five times before the test. Unless otherwise defined, test and measurement shall be done under temperature of $25\pm 3^{\circ}\text{C}$ and relative humidity of 45~85%. The test results are not affected evidently by such conditions of temperature $15\sim 30^{\circ}\text{C}$ or humidity 25~85%RH.

测试电池必须是本公司出厂时间不超过一个月的新电池，且电池未进行过五次以上充放电循环。除非其他特殊要求，本产品规格书规定的测试的环境条件为：温度 $25\pm 3^{\circ}\text{C}$ ，相对湿度 45%~85%。温度 $15\sim 30^{\circ}\text{C}$ 或者相对湿度 25~85%对测试结果没有明显影响。

Standard 依据标准

本产品依据标准：GB/T 18287-2013 This product is based on the standard of: GB / T 18287-2013

3.3 Standard Charge 标准充电

Test procedure and its criteria are referred as follows:

$0.2\text{CmA}=288\text{mA}$

Full charge condition: Constant current 0.2CmA , Constant voltage 4.35V to 0.02CmA for 6.5hours in all at $25\pm 3^{\circ}\text{C}$.

$25\pm 3^{\circ}\text{C}$ 环境下充电， 0.2CmA 4.3V(CC-CV) 截止电流为 0.02CmA ，总充电时间不超过 6.5 小时。

3.4 Electrical Performance 电性能测试

3.5.1 Temperature Dependence of Capacity (Discharge) 放电温度特性

Cells shall meet the discharge capacity requirements listed in the below table under respective discharge temperatures. The capacities are to be measured with constant discharge current 0.2CmA (3.4V cut-off) after standard charge at $25\pm 3^{\circ}\text{C}$.

电池在 $25\pm 3^{\circ}\text{C}$ 标准充电，然后在 30 分钟内冷却或加热到测试温度。放电前电池在此温度下保持 2.5 小时，放电电流为 0.2CmA (3.4V 关断)，做完一个温度实验后，电池在室温下放置 2h 然后进行充电 ($25\pm 3^{\circ}\text{C}$)，要求如下：

Discharge Temperature 放电温度	-10°C	25°C	60°C
Discharge Capacity 放电容量	50%	100%	95%

3.5.2 Cycle Life 循环性能

10min rest period after 0.5CmA charge, 0.2CmA discharge to a cut-off voltage of 3.4V, 10min rest period, repeat the above step, the capacity shall be measured at 300th. Capacity retention after 300 cycles $\geq 80\%$

0.5CmA 充电后，搁置 10min， 0.2CmA 放电至 3.4V，搁置 10min，重复上述步骤，直到第 300 周循环结束，测试温度 $25\pm 3^{\circ}\text{C}$ (影响电池循环性能的重要参数)，要求如下：

容量保持率 (300 周) $\geq 80\%$

深圳市海芝通电子股份有限公司

Shenzhen Hi-Chipcom Electronics Co.,Ltd

4 Initial Performance Test 初始性能测试

Item	Measuring Procedure	Requirements
(1) Open-Circuit Voltage 开路电压	The open-circuit voltage shall be measured within 24 hours after standard charge. 标准充电后 24 小时内测试	$\geq 4.2V$
(2) AC Impedance Resistance 内阻	The Impedance shall be measured in an alternating current method (1kHz LCR meter) after standard charge at $25 \pm 3^{\circ}C$. $25 \pm 3^{\circ}C$ 环境下, 标准充电后用交流阻抗法测试	$\leq 150m \Omega$
(3) Minimum Capacity 最小容量	The capacity on 0.2CmA discharge shall be measured after standard charge at $25 \pm 3^{\circ}C$ (specified C_5). $25 \pm 3^{\circ}C$ 环境下, 标准充电后以 0.2CmA 恒流放电至截止电压时所放出的容量 (即 C_5)。	Discharge Capacity $\geq 100\%$ 放电容量 $\geq 100\%$
(4) 0.5CmA Discharge Capacity 0.5C 放电容量	The capacity on 0.5CmA discharge shall be measured after standard charge at $25 \pm 3^{\circ}C$. $25 \pm 3^{\circ}C$ 环境下, 标准充电后以 0.5CmA 恒流放电至截止电压时所放出的容量。	Discharge Capacity $\geq 90\%$ 放电容量 $\geq 90\%$

5. Shelf Life 荷电保持能力

Item 项目	Measuring Procedure 测试方法	Requirements 要求
Storage Characteristics1 常温贮存	1 The capacity on 0.2CmA discharge shall be measured after standard charge and then storage at $25 \pm 3^{\circ}C$ for 30 days. 标准充电后电池在 $25 \pm 3^{\circ}C$ 的环境中贮存 30 天, 测试 0.2CmA 放电容量 (保持容量)	Remaining Capacity $\geq 85\% C_5$ 容量保持率 $\geq 85\%$
	2 After above measured Remaining capacity, the capacity on standard discharge shall be measured after standard charge. 0.2CmA 循环 3 次, 测试恢复容量 (3 周循环的最大放电容量)	Recovery capacity $\geq 90\% C_5$ 容量恢复率 $\geq 90\%$
Storage Characteristics2 高温贮存	1 The capacity on 0.2CmA discharge shall be measured after standard charge and then storage at $60 \pm 2^{\circ}C$ for 7 days. 标准充电后电池在 $60 \pm 2^{\circ}C$ 的环境中贮存 7 天, 测试 0.2CmA 放电容量 (保持容量)	Remaining Capacity $\geq 60\% C_5$ 容量保持率 $\geq 60\%$

深圳市海芝通电子股份有限公司

Shenzhen Hi-Chipcom Electronics Co.,Ltd

	2	<p>After above measured Remaining capacity, the capacity on standard discharge shall be measured after standard charge.</p> <p>0.2CmA 循环 3 次, 测试恢复容量 (3 周循环的最大放电容量)</p>	<p>Recovery capacity $\geq 80\% C_5$</p> <p>容量恢复率 $\geq 80\%$</p>
--	---	---	---

6. Mechanical Performance 机械性能

Item 项目	Measuring Procedure 测试方法	Requirements 要求
Vibration test 振动测试	<p>After standard charge, the battery is to be tested as following conditions:</p> <p>Amplitude:0.8mm</p> <p>Frequency:10~55Hz(sweep:1Hz/min)</p> <p>Direction: X/Y/Z axis for 90~100min. The battery is to be tested in three mutually perpendicular to each axis.</p> <p>标准充电后, 对电池施加振幅 0.8mm, 频率变化 1Hz/min, 频率范围 10~55Hz 的简谐振动, 振动时间约 90~100min。</p>	<p>No fire, no explosion, no smoking is obtained.</p> <p>不起火, 不爆炸, 不冒烟</p>
Drop Test 自由跌落	<p>Drop the battery in the shipment condition(full-charge)from 1m height onto 5cm or thicker concrete with p-tile on it 3 times each of X, Y, and Z directions at $25 \pm 3^\circ\text{C}$</p> <p>在 $25 \pm 3^\circ\text{C}$ 的环境条件下, 将电池进行 3 次从 1.0m 高度的位置自由跌落到水泥板上的试验。</p>	<p>No fire, no explosion, no smoking is obtained.</p> <p>不起火, 不爆炸, 不冒烟</p>

7. Safety Performance 安全性能

Item 项目	Measuring Procedure 测试方法	Requirements 要求
Short-Circuit Test 短路测试	<p>After standard charge, the battery is to be short-circuited by connecting the positive and negative terminals of the battery with copper wire having a maximum resistance load of 0.1Ω.</p> <p>标准充电后, 电池应在外电路总电阻不大于 0.1Ω 的铜线连接下进行短路试验。</p>	<p>No explosion, no fire.</p> <p>The temperature of the exterior cell casing shall not exceed 150°C.</p> <p>不爆炸, 不起火, 电池外部温度不超过 150°C</p>
Heating Test 热冲击	<p>A battery is to be heated in a gravity convection or circulating air oven. The temperature of the oven is to be raised at a rate of $5 \pm 2^\circ\text{C} / \text{min}$ to a temperature of $130 \pm 2^\circ\text{C}$ at which temperature the oven is to remain for 30 minutes before the test is discontinued.</p> <p>将电池放于热箱中, 温度以 $5 \pm 2^\circ\text{C}/\text{min}$ 的速率升至 $130 \pm 2^\circ\text{C}$ 并保温 30min.</p>	<p>No explosion, no fire.</p> <p>不爆炸, 不起火</p>

深圳市海芝通电子股份有限公司 Shenzhen Hi-Chipcom Electronics Co.,Ltd

Abnormal Charging Test 过充电	<p>After standard charge, the battery is subjected to a charging current by connecting it to a dc-power supply. The beginning current is 3.0C, which is to be obtained by connecting a resistor of specified size and rating in series with the battery, the voltage of the dc-power supply is 4.6V. The test time is 2.5 hours. This does not require that the initial I_c be maintained for 2.5 hours.</p> <p>标准充电后, 将电池正负极连接于恒压电源, 设置电流为 3.0C, 电压为 4.6V, 然后对电池以 3.0C 充电, 直至电压达到 4.6V, 并恒压保持 2.5 小时。</p>	No explosion, no fire. 不爆炸, 不起火
-------------------------------	---	------------------------------------

8.
9.

10. Battery configuration 电池组成

NO 序号	Item 项目	Criteria 标准	Remarks 备注
3.1	Cell 电芯	锂离子聚合物电芯 363290	
3.2	PCM 保护板	ML-5G-F PCM	单只
3.3	外观工艺辅料	高温防火绝缘胶、专用头贴纸	

11. Circuit Diagram 电路原理图

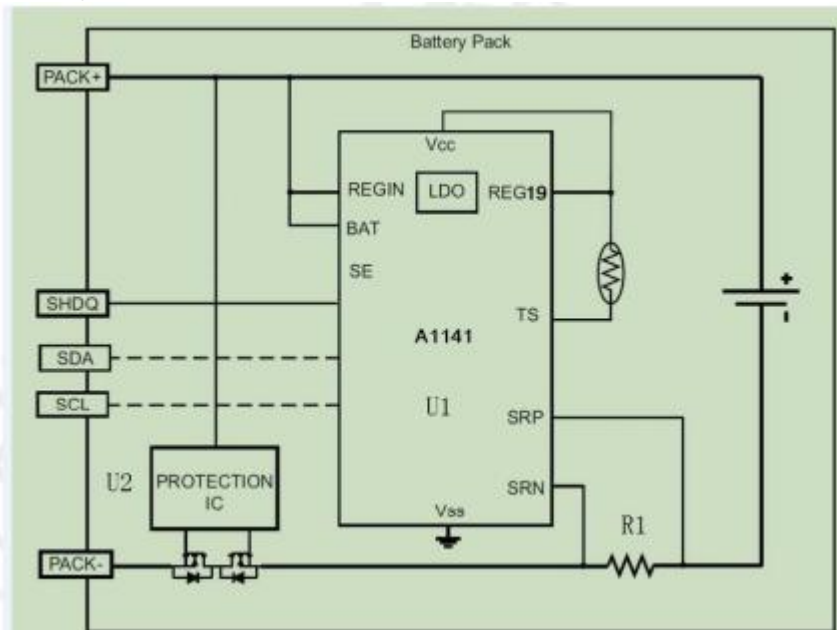

深圳市海芝通电子股份有限公司

Shenzhen Hi-Chipcom Electronics Co.,Ltd

12. PCM BOM

Item	Reference	Description	Type	Qty	Vendor
1	U1	IC	A1141	1	智旺
2	U2	MOSFET	ST711	1	ITM
3	R1	Resistor	10mΩ±1%	1	元玺科技

13. PCM parameter PCM 参数

No	Item	Condition	Specification
1	输入电压/input Voltage	B+/B-间输入电压/input Voltage B+ to B-	1.5V~+10V
2	过充电 Overcharge	保护电压/Detection voltage	4.3±0.02V
3		恢复电压/Release voltage	4.1±0.030V
4		保护延迟时间/ Detection delay time	0.8~1.3 S
5	过放电 Over discharge	保护电压/Detection voltage	2.50±0.07V
6		恢复电压/Release voltage	2.90±0.10V
7		保护延迟时间/ Detection delay time	55~115.2 ms
8	放电过电流 Over discharge current	放电过流保护电流/Over current	3.0~5A
9		放电过流保护延时/delay time	6~15.6 ms
10	充电过电流 Over charge current	充电过流保护电流/Over current	3.0~5A
11		充电过流保护延时/delay time	6~10.4ms
12	短路保护 Short detection	短路保护延时/ Short detection delay time	210~760us
13		恢复条件/Release Conditions	断开负载/Cut off load
14	自耗电 consumption	工作状态/Normal model	Max 6.0uA
15	0V 充电/0V charging	是否允许 0V 充电/allowed 0V charging	YES

备注：以上参数基于 25℃测试

14. Communication test (diagrammatic sketch) PC 通讯测试 (示意图)

深圳市海芝通电子股份有限公司 Shenzhen Hi-Chipcom Electronics Co.,Ltd

Name	Value	Unit	Log	Scan
ManufacturerAccess	0xe001	-	<input checked="" type="checkbox"/>	<input checked="" type="checkbox"/>
AtRate	0	mA	<input checked="" type="checkbox"/>	<input checked="" type="checkbox"/>
AtRateTimeToEmpty	189	min	<input checked="" type="checkbox"/>	<input checked="" type="checkbox"/>
Temperature	34.1	℃	<input checked="" type="checkbox"/>	<input checked="" type="checkbox"/>
Voltage	3464	mV	<input checked="" type="checkbox"/>	<input checked="" type="checkbox"/>
Battery Status	0x0105	-	<input checked="" type="checkbox"/>	<input checked="" type="checkbox"/>
NomAvailableCapacity	33	mAh	<input checked="" type="checkbox"/>	<input checked="" type="checkbox"/>
FullAvailableCapacity	11649	mAh	<input checked="" type="checkbox"/>	<input checked="" type="checkbox"/>
RemainingCapacity	33	mAh	<input checked="" type="checkbox"/>	<input checked="" type="checkbox"/>
FullChargeCapacity	11649	mA...	<input checked="" type="checkbox"/>	<input checked="" type="checkbox"/>
AverageCurrent	189	mA	<input checked="" type="checkbox"/>	<input checked="" type="checkbox"/>
TimeToEmpty	4	min	<input checked="" type="checkbox"/>	<input checked="" type="checkbox"/>
TimeToFull	65535	min	<input checked="" type="checkbox"/>	<input checked="" type="checkbox"/>
StandbyCurrent	-12	mA	<input checked="" type="checkbox"/>	<input checked="" type="checkbox"/>
STTE	155	min	<input checked="" type="checkbox"/>	<input checked="" type="checkbox"/>

Name	Value	Unit
MaxLoadCurrent	-2606	mA
MLTTE	0	min
Avail Energy	11650	mWh
Average Power	654	mW
InternalTemperature	34.1	℃
CycleCount	2	-
StateOfCharge	0	%
StateOfHealth	100	%
PassedCharge	-34	mAh
DOD0	10000	-
TTECP	11	min
Pack Configure	0x8930	-
DesignCapacity	11500	mAh
DeviceName	27541	-

Battery Status	0x105	Control status	0xe001	Pack Configure	0x89
OTC	OTD	RSVD	RSVD	SE	FAS
				SS	CSV
				RESCAP	RSVD
				RSV	

15. Handling Instructions 电池使用指南

Read and observe the following warnings and precautions to ensure correct and safe use of Li-ion batteries.

阅读并遵守下列警告及注意事项，以确保锂离子电池的正确及安全使用。

Danger!

Failure to observe the following precautions may result in battery leakage, overheating, explosion and/or fire.

- Do not immerse the battery in water or allow it to get wet.
- Do not use or store the battery near sources of heat such as a fire or heater.
- Do not use any chargers other than those recommended by ML.
- Do not reverse the positive(+) and negative(-) terminals.
- Do not connect the battery directly to wall outlets or car cigarette-lighter sockets.
- Do not put the battery into a fire or apply direct heat to it.
- Do not short-circuit the battery by connecting wires or other metal objects to the positive(+) and negative(-) terminals.
- Do not carry or put the battery together with necklaces, hairpins or other metal objects.
- Do not strike, throw or subject the battery to sever physical shock.
- Do not pierce the battery casing with a nail or other sharp object, break it open with a hammer, or step on it.
- Do not directly solder the battery terminals.
- Do not attempt to disassemble or modify the battery in any way.
- Do not recharge the battery near a fire or in extremely hot conditions.
- Do not short-circuit the battery by connecting the negative(-) terminal to the packing foil in battery assembling.

危 险!

不仔细阅读下述事项可能导致电池泄露、爆炸或起火。

- 勿将电池投入水中或将其弄湿；
- 勿在热源（如火或加热器）附近使用或贮存电池；

深圳市海芝通电子股份有限公司

Shenzhen Hi-Chipcom Electronics Co.,Ltd

- 请使用原厂充电器；
- 勿将正负极接反；
- 勿将电池直接连接到墙上插座或车载点烟式插座上；
- 勿将电池投入火中或给电池加热；
- 禁止用导线或其他金属物体将电池正负极短路，
- 禁止将电池与项链、发夹或其他金属物体一起运输或贮存；
- 禁止撞击、投掷或者使电池受到机械震动；
- 禁止用钉子或其他尖锐物体刺穿电池壳体，禁止锤击或脚踏电池；
- 禁止直接焊接电池端子；
- 禁止以任何方式分解电池；
- 禁止在火源或极热条件下给电池充电；
- 电池装配中，严禁负极与包装膜短路。

Warning!

Failure to observe the following precautions may result in battery leakage, overheating, explosion and/or fire.

- Do not place the battery in a microwave oven or pressurized container.
- Do not use the battery in combination with primary batteries(such as dry-cell batteries) or batteries of different capacity, type or brand.
- Do not use the battery if it gives off an odor, generates heat, becomes discolored or deformed, or appears abnormal in any way. If the battery is in use or being recharged, remove it from the device or charger immediately and discontinue use.
- Keep the batteries out of the reach of children. If a child somehow swallows a battery , seek medical attention immediately.
- If the battery leaks or emits an odor, immediately remove it from the proximity of any exposed flame. The leaking electrolyte can ignite and cause a fire or explosion.
- If the battery leaks and electrolyte gets in your eyes, do not rub them. Instead, rinse them with clean running water and immediately seek medical attention. If left as is, electrolyte can cause eye injury.

警告!

不仔细阅读下述事项可能导致电池泄露、爆炸或起火。

- 禁止将电池置入微波炉或压力容器中；
- 禁止与一次电池（如干电池）或不同容量、型号、品种电池组合使用；
- 如果电池发出异味、发热、变形、变色或出现其他任何异常现象时不得使用；如果电池正在使用或充电，应立即从用电器中或充电器上取出并停止使用；
- 电池应放在小孩接触不到的地方，如果小孩不小心吞咽电池 应立即寻求医疗救助；
- 如果电池泄漏或发出异味，应立即将其从接近明火处移开；

深圳市海芝通电子股份有限公司

Shenzhen Hi-Chipcom Electronics Co.,Ltd

泄漏的电解液可能引起火灾或爆炸；

- 一 如果电池漏液后电解液进入眼睛，不要擦，应用水冲洗，立即寻求医疗救助。如不及时处理，眼睛将会受到伤害。

Caution!

Do not use or store the battery where is exposed to extremely hot, such as under window of a car in direct sunlight in a hot day. Otherwise, the battery may be overheated. This can also reduce battery performance and/or shorten service life.

Use the battery only under those environmental conditions described in this document. Failure to do so can result in reduced performance or a shorten service life. Recharging the battery outside of these temperatures can cause the battery to overheat, explode or catch fire.

In cases where children use the battery, instruct them on the contents of the user's guide and keep an eye on them to ensure that the battery is being used correctly.

If the battery leaks and electrolyte gets your skin or clothing, immediately rinse the affected area with clean running water. If left as is, skin inflammation can occur.

For directions on battery installation and removal, read the instruction manual that accompanies the equipment in which the battery will be used.

If a device is not used for an extended period, the battery should be removed and stored in a cool, dry place. Otherwise, resting or reduced performance may occur.

If the terminals of the battery are dirty, wipe them clean with dry cloth before use. Otherwise, solid electrical contact may not be charged with the equipment, and this can cause power outages or charging to fail.

注 意！

不要使用处于极热环境中的电池，如阳光直射或热天的车内。否则，电池会过热，可能着火（点燃），这样就会影响电池的性能、缩短电池的使用寿命。

只能在本规格书规定的环境条件下使用电池，否则将会降低电池的性能或缩短电池的使用寿命。在规定之外的温度下充电可能导致电池过热、爆炸或起火。

当小孩使用电池时，需要按用户说明书的内容教他们，并密切注意他们确保正确使用电池。

如果电池漏液，电解液弄到皮肤或衣服上，立即用流动的水清洗受影响区域，否则可能导致皮肤发炎。

阅读用电池的装置说明书，正确进行电池的安装与拆卸。

如果设备长期不用，将电池取出并放置在凉爽、干燥的地方，否则，电池可能生锈或性能变差。

如果电池的端子变脏，使用前用干布擦干净。否则电池会接触不良，从而引起能量损耗或无法充电。

本公司保留本规格书的各项规格的解释权及修改权，并不另行通知